

EZ ELECTRIC POWER STEERING
INSTALLATION MANUAL
MG MGB2

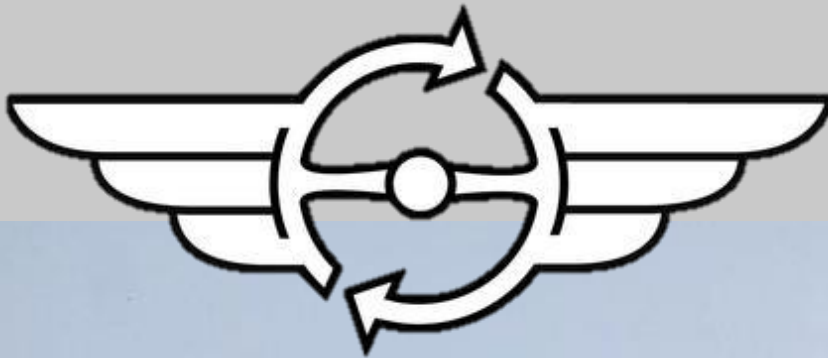

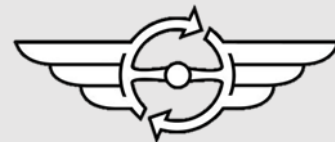

CONTENT

Het Product	1
Inhoud van de set.....	Fout! Bladwijzer niet gedefinieerd.
Voor en na de montage.....	Fout! Bladwijzer niet gedefinieerd.
Installatie	4



THE PRODUCT

Thank you for choosing an EZ ELECTRIC POWER STEERING product for its quality, it's performance, type approval and its straightforward assembly. Since 2006 we have been manufacturing complete steering columns with integrated electrical assistance. All columns are tailor made for each type of car and we have over 200 different types in stock. For more information about our products (power steering systems and replica steering wheels) or to place an order, visit our website www.ezpowersteering.com or send an e-mail to info@ezpowersteering.nl. If you have any questions of a technical nature please contact workshop@ezpowersteering.nl.

Version C1

Date 23/6/20

This installation manual must be read very carefully to avoid mistakes.

Check if all parts are present in the kit using the picture in the manual.

Compare the EZ Power Steering Column with the original column. Examine if the sizes are similar.

If you do not have the skills or tools to carry out the installation, then have a professional fit the kit for you.

EZ Power Steering cannot be held accountable for a faulty installation or damages to the kit or vehicle.



CONTENTS OF THE SET

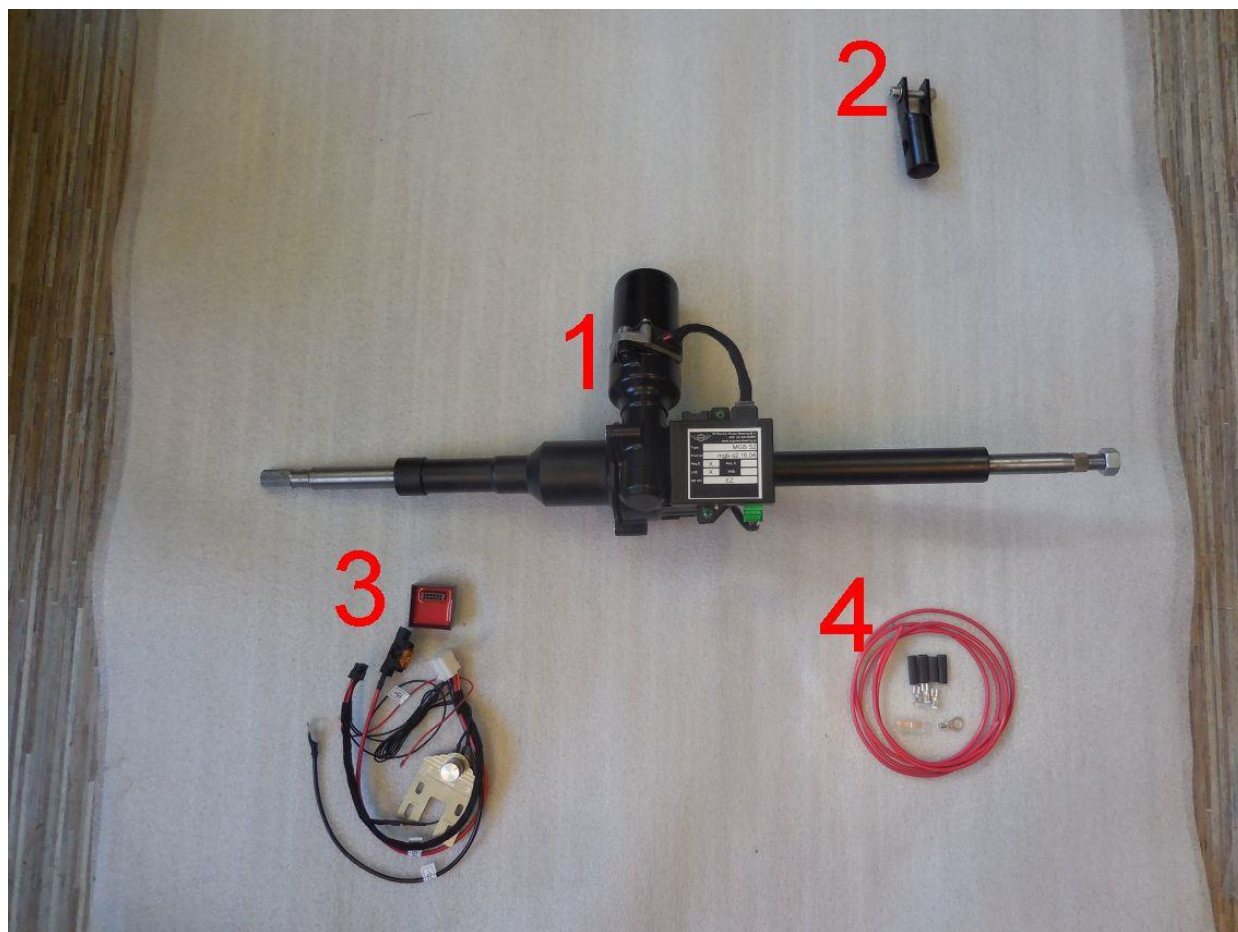



BEFORE AND AFTER ASSEMBLY



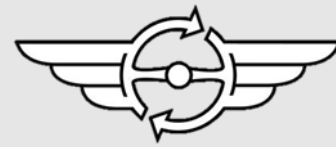

INSTALLATION

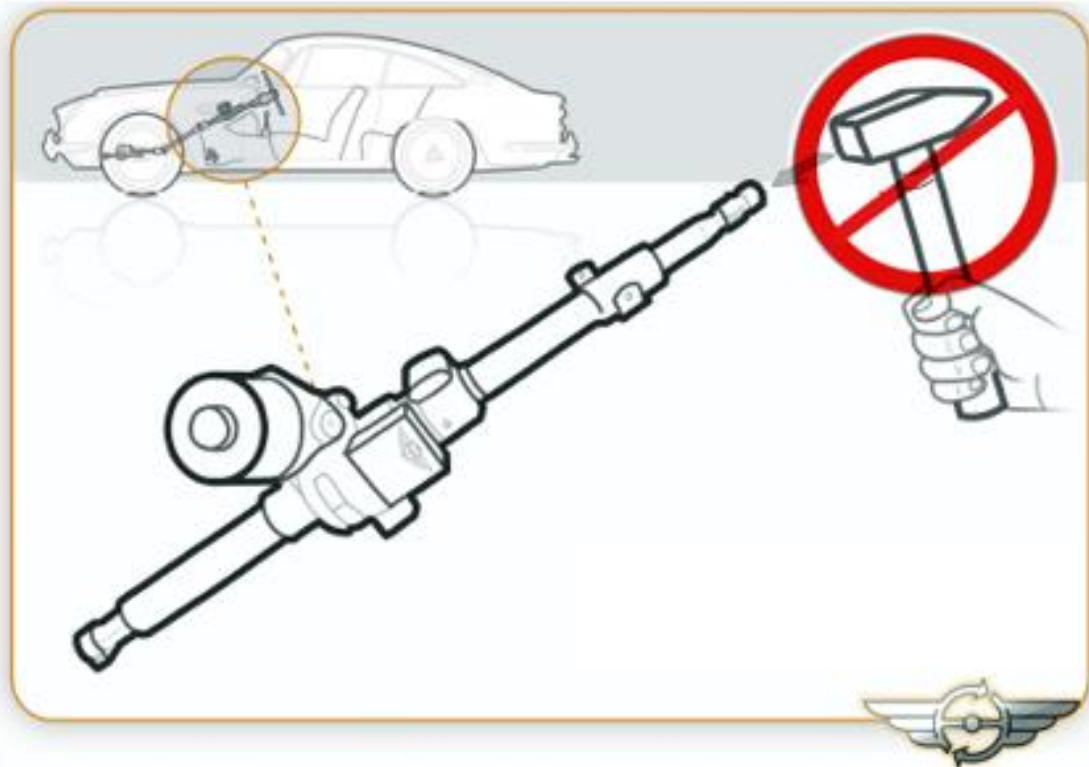

Never strike the input shaft with an object during or after assembly. This can adversely affect the sensors.

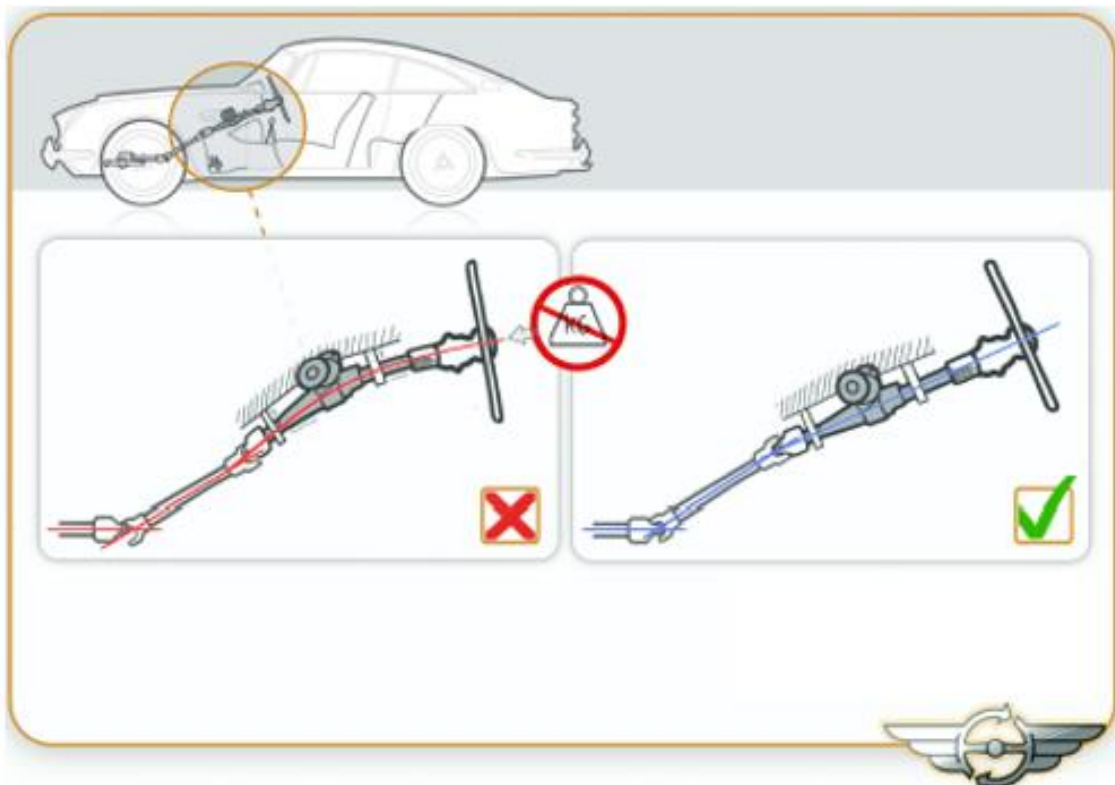

The steering system must always be properly aligned and mounted without tension.

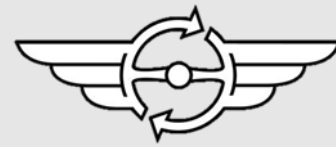

Step 1.

Check the tire pressure and test drive the car. Check that the handlebars return to the straight ahead position. Check that the controls and instruments are free from defects. If all this is in order, proceed with the conversion.

Step 2.

Find a contact-switched power supply. This is necessary for controlling the EZ power steering unit (see point 11). If present, disassemble the bottom plate under the dashboard, the switched power supply can either be removed from the ignition lock or the start button. Then disconnect the earth cable from the battery. Make a choice before installation, or put the wheels and steering wheel in the straight-ahead position, mark this position and proceed with the conversion. Or determine the center of the wheelhouse by dividing the number of steering turns, from full left to full right, by two and adjust wheel alignment as necessary after installation.

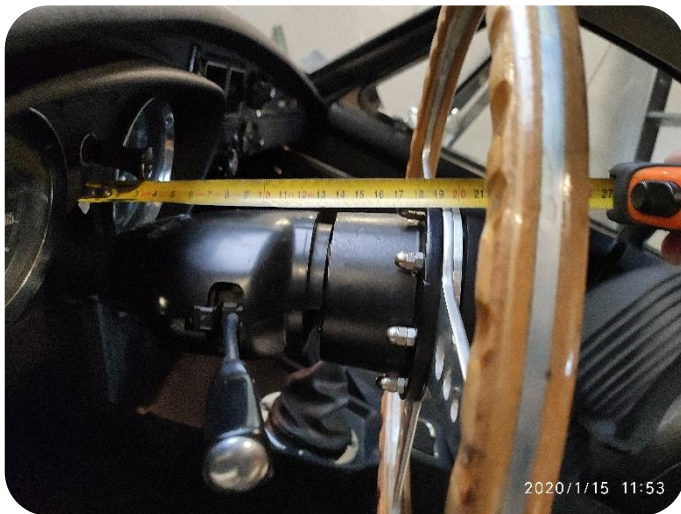

Step 3.

Measure the overhang of the handlebar relative to the dashboard. This should be approximately the same after installation.

Then remove the horn cap from the steering wheel.



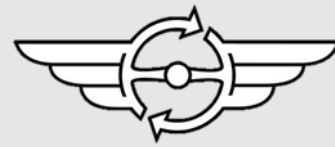

Step 4.

Remove the steering wheel. Pay attention to the turn signal turn. It must return to the same position later. Also remove the protective caps from the column.



Step 5.

Remove the air filter from the engine compartment. This is the only way to access the universal joint.

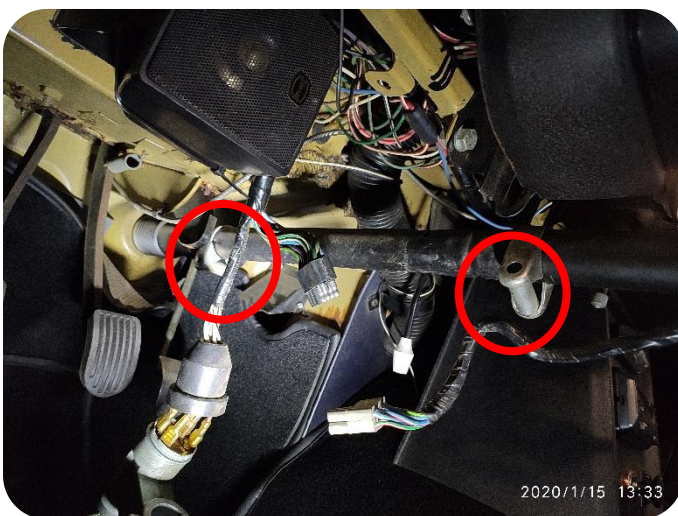

Step 6.

Remove the wiring and the two circled bolts. After this you can remove the entire steering column from the car.



Step 7.

Install the supplied ignition switch support, as shown in the photo. After that you can mount the original ignition lock again.

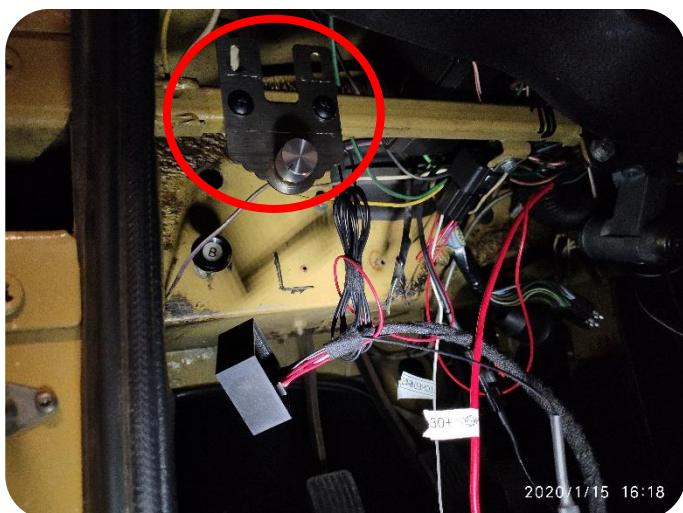
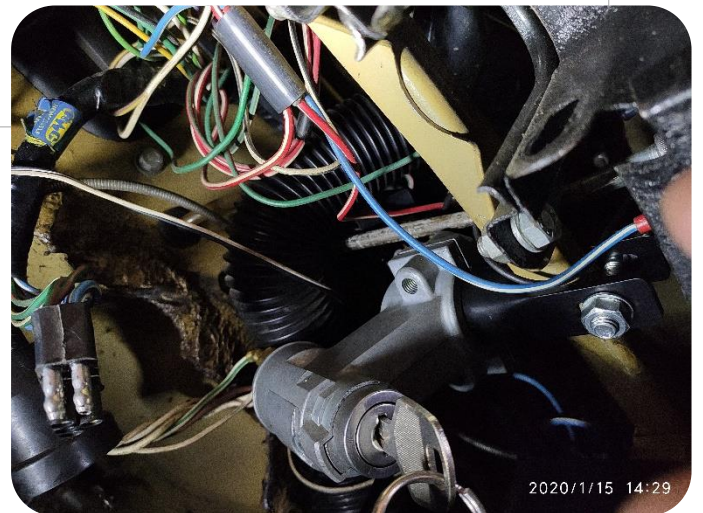
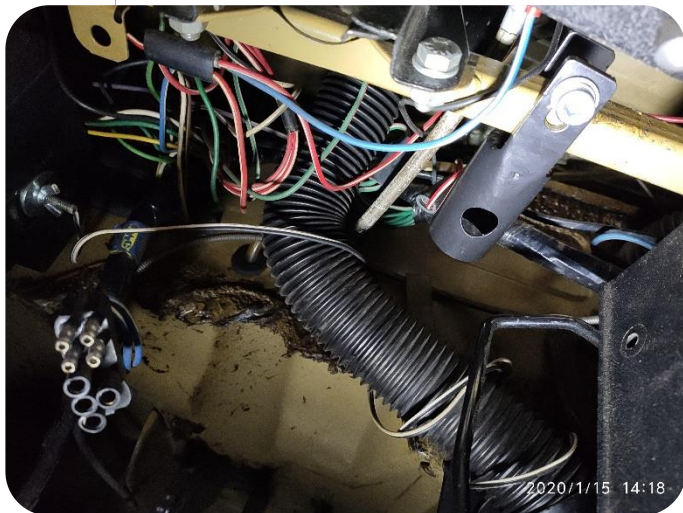

Step 8.

Mount the potentiometer or a suitable place under the dashboard

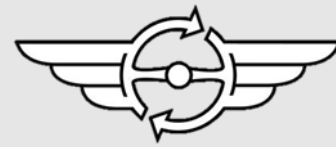

Step 9.

Connect the EZ wire set to the ECU.

Step 10.

Connect the thick red wire (30+) supplied via the fuse holder directly to the battery plus. It is advisable to insulate the wire with an extra jacket.

Step 11.

Connect the thin red wire (15+) to a contact switched power supply (see point 2)

Step 12.

Connect the black wire (31-) to a suitable clean ground point.

Step 13.

Install the previously disconnected earth cable from the battery. After switching on the ignition, a click is heard from the ECU, the system is now operational, check this by making steering movements. After switching off the ignition, a click is heard again after about 4 seconds. The system is then disarmed.

Step 14.

Reassemble the steering wheel of the car .. Take a test drive and check all the systems again. Also check whether the position of the steering wheel is mounted in the straight-ahead position.

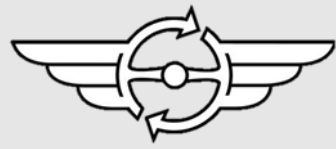

Step 15.

The end result.

